

Spiros Panigirakis

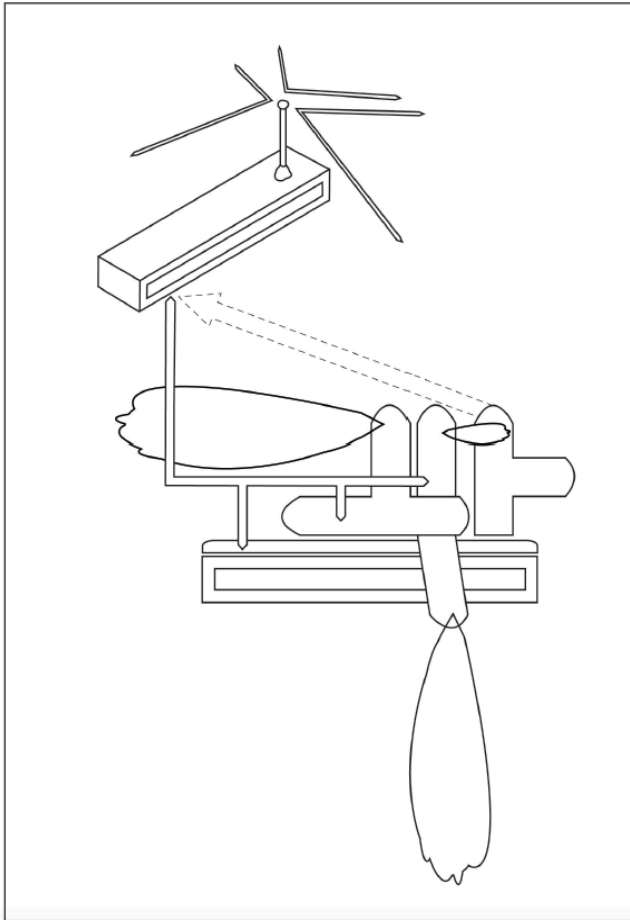

THE SALON. Over the last few years Melbourne has seen an increase in initiatives that utilise a spare room or some space within a domestic setting for the presentation of an art practice to a 'broader' audience. Dude Space, Apartment and Austral Avenue probably don't have the requisite hospitable conditions that the notion of the salon suggests – although Lyndal Walker's Springthing (2005) at the now defunct Dude Space might be an exception. The convivial social space of the backyard barbeque in Walker's project allowed a dialogical quality to infuse the space's decorative representations of abundance, growth and garlands.

Melbourne's Michael Graf has been consistently showing his refined canvas board projects for well over a decade in lounge rooms on both sides of the Yarra River. Shown during single Saturday afternoons to small audiences, sometimes with cake and tea, his paintings can't be separated from intimate and warm environment they are shown in. Regardless of how esoteric his references are and the clinical and delicate quality of his painted surfaces, Graf's practice is dedicated to the contemplation of a singular moment that shifts imperceptibly across the space of a few panels and in the quiet social space that accompanies it. These spaces replicate the space of the white cube with accompanied conversational launch/opening niceties and make obvious allowances to their domestic infrastructure in presentation.

So while the practical difference between this nouveau salon (with domestic connotations of the private and the exclusive) and the small independently-run space (with its more public profile regardless of the limits of its actual audience size) are minimal, the two models may also be seen as ideologically opposed. The position you adopt will probably reflect where you fall on the fraught question of how accessible you want your art to be. My use of the word "salon" might reflect a dubious romanticisation of the critical dialogue that might have occurred in Gertrude Stein's front room. Not to mention the incongruity between the exclusive class patronage of early twentieth century European cultures and the contemporary Australasian context. If we imagine a domestic space with its implicit associations of nurturing and of the drawn-out supportive feedback session – isn't this the space of the cliché? Or does it offer the rich possibilities a salon might still inhabit?

Spiros Panigirakis *Tentative Typology of Alternatives in Enjoy*, Critical Publics, 2008

Contemporary Art on the Road is a unique program that provides access to artists and art experts from some of Melbourne's leading art institutions. This resource was created to introduce teachers to a range of hands-on, expertly designed strategies and resources for teaching contemporary art in their classroom.

Contemporary Art on the Road is funded by the Department of Education and Training Victoria (DET) through the Strategic Partnerships Program (SPP) and partnered with the following organisations:



Contemporary Art on the Road is an initiative developed by Gertrude Contemporary and in partnership with Monash University Museum of Art, the Victorian Curriculum and Assessment Authority and three regional Victorian galleries: Latrobe Regional Gallery, Horsham Regional Art Gallery and Shepparton Art Museum.



About the Artist

Spiros Panigirakis is interested in the way in which presentational devices, furniture and organisational frameworks influence the construction of meaning, form and sociability. He has long engaged the role of the studio as a space of production in which results of artistic 'fieldwork' are synthesised and transformed. This research-led practice re-envisages situations of cultural and personal significance in the form of diagrams, mappings, manuals, texts and patterns as well as sculptural referents. Panigirakis often works with groups in both a curatorial and collaborative capacity to address the sited conditions of art and, when working on an individual basis, he alludes to these issues within the content of the work. 'Garden States' for example reflected on the relationships and rituals developed within the suburban gardens inhabited by Panigirakis' parents and their peers. A functional sculpture, it contained diagrammatic drawings depicting networks of people and social systems, reflecting Panigirakis' interest in the underlying structures of places and groups.

Spiros Panigirakis completed a PhD in 2011 at the Faculty of Art Design & Architecture at Monash University, where he has taught across the Theory Program, Sculpture, Painting and Drawing Departments. He was a finalist in the *Melbourne Prize for Urban Sculpture* in 2008 and 2014, and recent solo exhibitions have been held at: Edinburgh Gardens, 2013; WestSpace, 2012; Margaret Lawrence Gallery, Victorian College of the Arts, 2010; Gertrude Contemporary Art Spaces, 2006; CLUBSproject Inc., 2006; TCB Artist Space Inc., 2003 and 1st Floor Artist and Writers' Space, 2001. He created a major new work *Garden States* for *Melbourne Now* at the National Gallery of Victoria, 2013–14. Selected group shows include *Collected Collaborations* at Monash University Museum of Art in Melbourne, 2011; *Just what is it that makes today's interiors so seductive, so alluring?* at Light Projects in Melbourne, 2010; *Secrets From The Working Men's College* at RMIT Project Space, 2010; *redrawing* at RMIT Project Space and Contemporary Art Services Tasmania in Hobart, 2008; *workshop.non.stop* at LOOSE Projects, Sydney, 2007; *Omnipresents* at Gertrude Contemporary Art Spaces, 2007; collaborative commission with Christopher LG Hill for *SLAVE 4, Adelaide Biennale for Australian Art*, Gallery of South Australia, 2006; *SLAVE 3* at VCA Margaret Lawrence Gallery, 2005; *Smash Your own Window* at CLUBSproject Inc and *multiple MISCELLANEOUS alliances* at CLUBSproject Inc., 2004.

Spiros Panigirakis was a founding member of the artist-run initiative CLUBSproject Inc. and established Australian Studies in 2014, a collaborative project with Fiona Macdonald that continues the turn to publication in the work of both artists.

Resources

Artist Website: <http://spirospanigirakis.com/>

Gallery Website: <http://www.sarahscoutpresents.com/web/spiros-panigirakis/>

Academic Profile: <https://www.monash.edu/mada/about-us/people/academic-staff/spiros-panigirakis>

Australian Studies: <http://crossart.com.au/archive/97-2014-exhibitions-projects/260-australian-studies-fiona-macdonald-and-spiros-panigirakis>

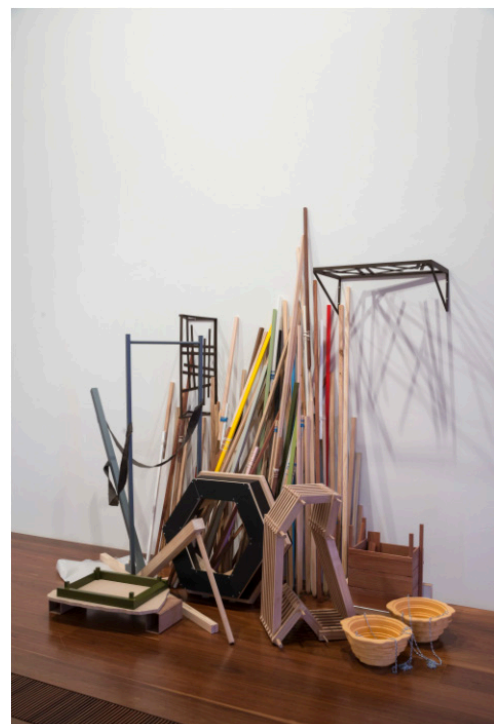

Image (right): Spiros Panigirakis, *Garden States*, 2013.

Workshop Summary

In this workshop participants will learn how research, writing and graphic posters can be used in the development and creation of artistic outcomes. This workshop explores the importance of diverse thinking and experimentation in contemporary art practice.

Introduction to craft and conceptual art (15 minutes): Spiros will give a presentation of historical precedents that contribute to his practice. This will look at Marcel Duchamp's sculptural output. The presentation will engage both Duchamp's critique of traditional craft and arguably the invention of series of material and technical strategies that are frequently used in contemporary art. The artist will also look at role of the diagram in Dada practice.

Artist talk (15 minutes): Presentation of Panigirakis' recent projects. These will be divided into material and technical strategies.

1. Wood - In the project *Ferntree Gully*, 2011, the artist followed DIY manual to construct a series of wooden stools. In *Close*, 2017, the artist learnt how to construct traditional panel door.
2. Posters - In a number of works, the artist uses Adobe Illustrator to draw out a range of ideas. This expanded notion of drawing utilises: the appropriation of different design sources; utilises decorative techniques aligned to décor; and uses the diagrammatic form to unpack a complex range of ideas.
3. Textile - currently Spiros is developing a project engaged in clothing and textile production. Using clothing patterns he is developing a series of costumes linked to a historical fictional text.

Workshop (1.5 Hours)

The workshop hones in on the conceptual development for a 2019 project that the artist is currently working on. This means the workshop will follow the artist's developmental process and explore how ideas are developed and made material and/or sculptural.

Currently Spiros is focussing in on Franz Kafka's *The Trial*. The artist re-reads Kafka's *The Trial* as a departure point for exploration of the unrelenting rule of indiscriminate and inescapable law; the bureaucratic systems that frame social relations; the representations of power; and the lived, embodied and visceral experiences that seep out from these apparatuses of control. The outcome of the workshop will be a graphic poster that will be presented within a sculptural context. The poster will be a response to an excerpt of text from Kafka's *The Trial*.

Research Phase

Taking a short passage from Kafka's *The Trial* – the workshop will focus on a series of experimental strategies that seeks not to illustrate the book of fiction but to use it as springboard to developing artworks that resonate with contemporary socio-political contexts.

Diagramming

Using online sources, texts provided by the artist and workshops discussions as catalyst – diagrams will be developed to represent a series of complex ideas relating both to Kafka's text but also to the workshop participants respective interpretation of the text. Participants will use the materials provided to map-out and draw their diagrams in form of a poster.

Posters and the display of the posters: The poster in Spiros' practice is always considered as an object in space. This means that presentation devices are developed to display the posters. In a number of artworks, the artist has utilised a sculptural poster-rack to display a suite of posters. To end the workshop, a series of experimental strategies will be developed to display the poster.

Summary

- Introduction (15 mins): Introduction to historical practice and thinking that inform his practice.
- Artist Talk (15 mins): Spiros will discuss recent projects and material interests
- Production phase (1.5 Hours): Participants will be led through the conceptualisation of a diagrammatic poster using Franz Kafka's *The Trial* as a catalyst.

Materials List

A3 Paper
Texta or felt tip pens

Pen
Ruler

Set Square
Protractor

Goals and Objectives

- Through critical and creative re-thinking of the typical mediums of visual art (eg. painting, sculpture, photography) - students will learn about poster art and how to situate their works within the canon of art history.
- Students will develop diagrammatic posters that link to conceptual ideas and expressions.
- Students will develop skills in research, conceptual thinking and visual art.
- Students are encouraged to think critically and creatively about the visual arts principals, materials and composition in a poster artwork.

The activity aims to:

- Expand students' knowledge about art histories, concepts and techniques.
- Encourage imagination and enjoyment through engagement with poster making and its display.
- Teach students to express themselves through conceptual thinking and diagrams.
- Expand student's critical and creative thinking, using visual languages and art history.

Learning Activity

Discussion

- Discuss Dada art and their influence on materials and techniques widely used in contemporary art (eg. found object). Who are significant artists that fit this category? (Teachers think: Marcel Duchamp, Kurt Schwitters, Andre Breton and Jean Arp).
- How does Spiros use the diagrammatic poster as a vehicle for his conceptual ideas? Do you think this is a good way to communicate complex ideas? Why? Why not?
- Talk about the use of craft in the arts. Look at the history and crossover of craft and the visual arts. Who are some contemporary artists that use craft methods in their practice?
- Think about the display of poster art in a gallery. Other than hanging them on walls, can you think of other ways to display them? What are the advantages and disadvantages of each display technique? How do they communicate or alter the meaning of the poster?

Concept Development

Students should begin by examining Spiros' website, his use of craft, and the history and cross over between visual arts and craft. They should discuss significant historical and contemporary examples of artists that blur the lines between the two fields. Students should build a collection of images from artists (contemporary or historical) who have used posters to convey ideas or meaning (Think: Henri de Toulouse-Lautrec, El Lissitzky, Gorilla Girls).

Production

Participants will begin the process by reading an excerpt of Kafka's *The Trial*. The group will discuss the text drawing out ideas, themes and concepts the text communicates to them. Through these discussions Spiros will lead the group to think about these themes conceptually and how they could be communicated through visual signs and symbols. Participants will use simple and accessible materials (paper, pens, rulers) to draw their diagrammatic drawings onto a poster.

Once poster have been completed further discussion will consider different modes of presentation and their meaning. Participants will be encouraged to think of their work as an object in space, rather than a

Links to Curriculum

PRIMARY & SECONDARY

Present & Perform

View the location and exhibition of Spiros' work. The students then plan their own exhibition of their artworks. They should consider the audience of the artworks and how they wish the audience to interpret the artwork.

Respond & Interpret

Level F – 6

Respond to Spiros' artwork by identifying and describing technique and ideas. Consider how he makes his work. Students could also discuss the range of aesthetic styles throughout art history.

Level 7 – 10

Analyse and interpret Spiros' artworks discussing ideas and viewpoints. Compare his work with works by other contemporary artists to identify characteristics and features of the works.

Explore & Express

Levels F – 6

Investigate the ways in which Spiros explores ideas, techniques and materials in his artworks. How are these expressed?

Levels 7 – 10

Explore the practices of Spiros. Through a discussion of Spiros' use of craft and found object, discuss how he expresses his ideas and develops a particular style within his work. Discuss his work in terms of the themes that he explores. From this discussion students should develop their own artistic practice through the use of inspiration, materials, techniques and processes to develop their own artworks.

Visual Arts Practice

Levels F – 6

Based on the artworks of Spiros students should explore materials, techniques, processes and visual conventions. They describe the use of these in the production of their artworks.

Levels 7 – 10

Think about the intentions that Spiros has when he commences making his work. Discuss his artistic practice. Using the artworks of Spiros as a starting point, explore materials, techniques, visual conventions and processes to develop an individual artistic intention.

VICTORIAN CERTIFICATE OF EDUCATION (VCE)

Studio Arts

Unit 1 Area of Study 3: Interpreting art ideas and use of materials and techniques: The work of artists from different times and cultures is studied to gain a broader understanding of how artworks are conceived, produced and exhibited. Students discuss the way in which Spiros has used materials and techniques, and interpreted ideas and sources of inspiration in producing his artworks.

Unit 2 Area of Study 2: Ideas and Styles in Artwork: Students develop an understanding of the use of other artists' works in the making of new artworks, which may include the ideas and issues associated with appropriation such as copyright and artists' moral rights. Discuss how Spiros uses of Franz Kafka's *The Trial*. How does Spiros use, or appropriate this text? Why might he choose a text as a point of departure for his visual outcomes?

Unit 3 Area of Study 3: Artists and Studio Practices: In this area of study students focus on professional studio practices in relation to particular art forms. Students should investigate the ways in which artists have interpreted subject matter, influences, historical and cultural contexts, and communicated ideas and meaning in their artworks. Students should examine Spiros' artist biography to understand the path of his professional development.

Unit 4 Area of Study 3: Art Industry Contexts

You will visit a variety of art exhibitions and examine the different methods and roles undertaken in the preparation and presentation of art to the public. Through his website examine several of Spiros' exhibition outcomes. Discuss the presentation methods used and what they communicate to the viewer.

Glossary

Initiative - the power or opportunity to act or take charge before others do. To show initiative, you are showing you can do something without being asked.

Domestic - relating to the running of a home or to family relations OR existing or occurring inside a particular country; not foreign or international.

Requisite - a thing that is necessary for the achievement of something else. For example, if you are doing a project on a book in an English class, it is a requisite that you read the book!

Hospitable - Friendly and welcoming to visitors or guests. In the case of a "hospitable environment", this means a similar thing – it means an environment that is pleasant and favourable for living in.

Convivial - Friendly, lively, and enjoyable. The term can be used in relation to either an atmosphere/event.

Dialogical - Dialogic refers to anything relating to dialogue, or conversation. If you are studying the dialogical quality of something, this means you are looking at the conversational patterns in it.

Infuse - to fill someone or something with an emotion or quality.

Garland - A wreath of flowers and leaves, worn on the head or hung as a decoration.

Refined - Elegant and cultured in appearance, manner, or taste.

Esoteric - intended for or likely to be understood by only a small number of people with a specialized knowledge or interest.

Clinical quality - Clinic can be defined as very efficient and without feeling; coldly detached. Think of a doctor's clinic, they are very white and sanitized! Something with a clinical quality has a cold and detached feeling to it.

Contemplation - The action of looking thoughtfully at something for a long time, or thinking hard about something for a while.

Imperceptible - So slight, gradual, or subtle as not to be perceived. Something almost undetectable – like grass growing.

Niceties - A fine or subtle detail or distinction.

Infrastructure - the basic physical and organizational structures and facilities (e.g. buildings, roads, power supplies) needed for the operation of a society or enterprise.

Nouveau salon - Nouveau is a French word that translates to modern or up to date. Salon can mean a regular meeting of important or influential people, esp. of writers or artists at the house of someone famous.

Independently-run spaces - Spaces run without government interference. Unlike government galleries, independently-run spaces are more free to do what they want as they have less rules and regulations. They are similar to an artist-run space, which is a gallery facility operated by creators such as painters or sculptors, thus circumventing the structures of public (government-run).

Connotation - something suggested or implied by a word or thing, rather than being explicitly named or described.

Ideologically - You can use the word ideological to describe shared ideas or beliefs.

Fraught - Full of unpleasant things such as problems or dangers.

Dubious - If you describe something as dubious, you mean that you do not consider it to be completely honest, safe, or reliable.

Incongruity - Incongruity means out of place — something that doesn't fit in its location or situation.

Implicit - Suggested though not directly expressed. Implied rather than explained.

Cliché - a phrase or opinion that is overused and betrays a lack of original thought.

Presentational devices - Something used to present something – often a secondary object. For example, a frame is a presentational device of an artwork. You might not necessarily see the frame as a part of the artwork because it is just there to show it. A plinth is another example.

Sociability - the quality of being sociable. Friendliness.

Synthesise - To combine a number of things into a coherent whole.

Re-envisage - To contemplate or conceive of a possibility or a desirable future event.

Referents - The thing in the world that a word or phrase denotes or stands for.

Allude - To suggest or call attention to something indirectly.

Ritual - A religious or solemn ceremony consisting of a series of actions performed according to a prescribed order.

Conceptual - Relating to or based on mental concepts.

Unrelenting - Extremely determined; never becoming weaker or admitting defeat.

Bureaucratic - Over-concerned with procedure at the expense of efficiency or common sense.

Visceral - Relating to deep inward feelings and emotional reactions rather than reason.

Apparatuses - Another word for tools or equipment.

Assessment Rubric – Contemporary Artist Practice – Level 4

Visual Arts Level 4 Achievement Standard

Students investigate the ways in which the artist explores ideas, techniques and materials in their work and plan their own art works.

Step 1	Step 2	Step 3	Step 4	Step 5
<p><i>Students identify the artist use of materials and techniques.</i></p>	<p><i>Students describe artist's use of materials and techniques and representation of ideas.</i></p> <p><i>There is a link between the artist's work and the student's work.</i></p>	<p><i>Students identify the ideas that the artist has explored in their work. These ideas are reflected in the student work.</i></p>	<p><i>Students describe the artist has explored ideas, materials and techniques in their work. The student has used the same ideas in their own work.</i></p>	<p><i>Students evaluate how the artist has explored ideas, materials and techniques in their work. The student can link the use of ideas, materials and techniques in their own work and link it to the artists work.</i></p>

Organising element	Action	Insufficient Evidence	Quality criteria				
<i>Exploration of artist use of materials and techniques</i>	<i>Documentation of materials and techniques in relation to ideas.</i>	<i>Insufficient Evidence</i>	<i>Materials are identified in the artist work.</i>	<i>Materials and techniques are discussed in short sentences.</i>		<i>Materials and techniques are described and related to ideas in the work.</i>	<i>Materials and techniques are analysed in relation to ideas. The artist's exploration is described.</i>
<i>Student use of materials and techniques.</i>	<i>Exploration of materials and techniques in relation to artists work.</i>	<i>Insufficient Evidence</i>	<i>Use of materials and techniques are evident.</i>	<i>Materials and techniques are explored in drawings.</i>	<i>Materials and techniques are explored with annotated drawings that relate to the artist's ideas.</i>	<i>Materials and techniques are explored demonstrating the student's own personal ideas that relate to the artist's ideas. There are some annotations.</i>	<i>Materials and techniques are explored through annotated drawings demonstrating the students own personal ideas that relate to the artist's ideas.</i>
<i>Art work planning</i>	<i>Students plan their own artwork.</i>	<i>Insufficient Evidence</i>	<i>A plan is evident in the visual diary.</i>	<i>The artwork plan documents the use of materials and techniques and student ideas.</i>	<i>The artwork plan relates to the exploration of materials and ideas and the artist's work.</i>	<i>The artwork plan demonstrates an exploration of materials and techniques that relates to the artist's ideas and work.</i>	<i>The artwork plan demonstrates an exploration of materials and techniques that builds on previous work and expands on the ideas expressed by the artist.</i>

Learning continuum and Formative assessment rubric– Level 4 - 6

VISUAL DIARY – The purpose of a visual diary is to document the creative process from inspiration through to reflection to improve their visual arts practice.

<p>By the end of Level 4</p> <ul style="list-style-type: none"> Students plan and make artworks that are inspired by artworks they experience. They discuss and evaluate the art making processes, materials and techniques they use to express their ideas. <p>By the end of Level 6</p> <ul style="list-style-type: none"> Students explain how ideas are expressed in artworks they make and view. They describe the influences of artworks and practices places on their artmaking.

Curriculum Span:			
Step 1	Step 2	Step 3	Step 4
<p>Students at this stage have attempted with assistance to use their visual diary to plan, research and document. Annotations and drawings show some links to artists being explored. Some documentation or verbal discussion of visual conventions.</p>	<p>Students at this stage students have attempted with some assistance to use their visual diary to plan, research and document. Annotations and drawings show some links to artists being explored. Visual conventions and purpose are used to document their thinking.</p>	<p>Students at this stage have independently used their visual diary to plan, research and experiment artworks in their visual diary that express some ideas and show how they have been influenced by artists being explored. Visual conventions and purpose are used to document their thinking.</p>	<p>Students at this stage explicitly plan, research, annotate and experiment artworks in their visual diary that express a wide range of ideas and clearly show how they have been influenced by artists being explored. Students have generated their own viewpoint within their planning. Visual conventions and purpose are used to document their thinking.</p>

Organising element/s	Action		Quality criteria			
Preliminary planning	Skill – use of visual conventions	Insufficient evidence	Draws using media.	Draws using the media to create visual conventions,	Draws using techniques with the media to create visual conventions.	Draws demonstrating technical control of the media to create visual conventions.
	Concepts -expresses ideas, meaning and emotion based on stimulus	Insufficient evidence	Draws subject matter.	Draws ideas that respond to the stimulus.	Expresses ideas through drawings that build on the ideas in the stimulus material.	Expresses ideas through drawings that extend on the ideas in the stimulus material to present a personal viewpoint.
Annotations to explain	Annotation of materials and techniques for preliminary drawings and experimentation	Insufficient evidence	Annotates using key words.	Annotations identifying properties of materials, techniques and visual conventions	Annotations describe the properties of materials, technique and visual conventions	Annotations describe and evaluate the use of materials, techniques and visual conventions to communicate the meaning of the artwork.
	Annotation of relationship to artist/inspiration material. (Book, Artist, Inquiry, Object)	Insufficient evidence	Identifies the artist	Describes the visual elements within their own work and the artwork studied.	Relates observations to ideas by describing the visual conventions used in their own and the artist's and/or artwork.	Explains observational and conceptual ideas by comparing the visual conventions, concepts and/or style/period between their own and the artist's artwork.

Level 5/6 Media Arts

Learning Continuum & Formative Assessment Rubric

<p>Level 6 Achievement Standard</p> <p>By the end of Level 6, students explain how viewpoints, ideas and stories are shaped and portrayed in media artworks they make, share and view.</p>	<i>Curriculum Span:</i>			
	<i>Step 1</i>	<i>Step 2</i>	<i>Step 3</i>	<i>Step 4</i>
	<i>Students structure a media product.</i>	<i>Students develop an understanding of audience and purpose in a media product.</i>	<i>Students structure a media product demonstrating the relationship of audience and purpose.</i>	<i>Students use intent and structure in a media product for a specific audience and purpose.</i>

Organising element/s	Action		Quality criteria			
Planning of a media product with purpose for a targeted audience.	Selection of message with purpose.	<i>Insufficient evidence</i>	<i>Selects message</i>	<i>Selects message for a purpose</i>	<i>Selects message for a purpose and audience.</i>	<i>Selects a message with intention for a specific audience and purpose.</i>
	Communication of ideas through documentation and storyboard	<i>Insufficient evidence</i>	<i>Lists ideas in dot points.</i>	<i>Identifies ideas relating to message.</i>	<i>Describes ideas relating to message.</i>	<i>Expands on ideas relating to intention and message.</i>
	Development of story line and characters in animation.	<i>Insufficient evidence</i>	<i>Sequenced story line</i>	<i>Story line connects to purpose.</i>	<i>Story line connects to purpose and audience.</i>	<i>Story line explains specific purpose of the message to the intended audience.</i>

Formative Assessment Rubric – Contemporary Artist Practice – Level 6

<p>Visual Arts Level 6 Achievement Standard</p> <p>Students explain how ideas are expressed in artworks they make and view. They demonstrate the use of different techniques and processes in planning and making artworks.</p>
--

Step 1	Step 2	Step 3	Step 4	Step 5
<p><i>Students identify the artist use of materials and techniques.</i></p>	<p><i>Students describe artist's use of materials and techniques and representation of ideas.</i></p> <p><i>There is a link between the artist's work and the student's work.</i></p>	<p><i>Students identify the ideas that the artist has explored in their work. These ideas are reflected in the student work.</i></p>	<p><i>Students describe the artist has explored ideas, materials and techniques in their work. The student has used the same ideas in their own work.</i></p>	<p><i>Students evaluate how the artist has explored ideas, materials and techniques in their work. The student can link the use of ideas, materials and techniques in their own work and link it to the artists work.</i></p>

Organising element	Action	Insufficient Evidence	Quality criteria				
<p><i>Exploration of artist use of materials and techniques</i></p>	<p><i>Documentation of materials and techniques in relation to ideas.</i></p>	<p><i>Insufficient Evidence</i></p>	<p><i>Materials are identified in the artist work.</i></p>	<p><i>Materials and techniques are discussed in short sentences.</i></p>		<p><i>Materials and techniques are described and related to ideas in the work.</i></p>	<p><i>Materials and techniques are analysed in relation to ideas. The artist's exploration is described.</i></p>
<p><i>Student use of materials and techniques.</i></p>	<p><i>Exploration of materials and techniques in relation to artists work.</i></p>	<p><i>Insufficient Evidence</i></p>	<p><i>Use of materials and techniques are evident.</i></p>	<p><i>Materials and techniques are explored in drawings.</i></p>	<p><i>Materials and techniques are explored with annotated drawings that relate to the artist's ideas.</i></p>	<p><i>Materials and techniques are explored demonstrating the student's own personal ideas that relate to the artist's ideas. There are some annotations.</i></p>	<p><i>Materials and techniques are explored through annotated drawings demonstrating the students own personal ideas that relate to the artist's ideas.</i></p>
<p><i>Art work planning</i></p>	<p><i>Students plan their own artwork.</i></p>	<p><i>Insufficient Evidence</i></p>	<p><i>A plan is evident in the visual diary.</i></p>	<p><i>The artwork plan documents the use of materials and techniques and student ideas.</i></p>	<p><i>The artwork plan relates to the exploration of materials and ideas and the artist's work.</i></p>	<p><i>The artwork plan demonstrates an exploration of materials and techniques that relates to the artist's ideas and work.</i></p>	<p><i>The artwork plan demonstrates an exploration of materials and techniques that builds on previous work and expands on the ideas expressed by the artist.</i></p>